

# DESIGN NOTES

## 60V/3A Step-Down DC/DC Converter Maintains High Efficiency over a Wide Input Range – Design Note 301

Mark Marosek

### Introduction

Today's high voltage applications—such as automotive, industrial and FireWire® peripherals—place increasing demands on power supplies. They must provide high power, high efficiency and low noise, in a small space and over an ever widening range of operational input voltages. Many high voltage DC/DC converter solutions can meet some of these conditions at high input voltages but they are unable to maintain high efficiencies at lower input voltages. Many of these same converters have frequency compensation schemes that require bulky input and output capacitors, which not only increase the size of the overall solution but also result in high output ripple voltage. The LT®3430 is designed to alleviate all of these problems.

The LT3430 is a monolithic step-down DC/DC converter which utilizes a 3A peak switch current limit and has the ability to operate with a 60V input. The LT3430 runs at a fixed frequency of 200kHz and is housed in a small thermally enhanced 16-pin TSSOP package enabling it to save space while optimizing thermal management. Its 5.5V to 60V input range makes the LT3430 ideal for FireWire peripherals (typically 8V to 40V input), as well as

automotive systems requiring 12V, 24V and 42V input voltages (with the ability to survive load dump transients as high as 60V). Furthermore, it was designed to maintain excellent efficiencies with both high and low input-to-output voltage differentials. Its current mode architecture adds flexible frequency compensation allowing the use of a ceramic output capacitor—resulting in small solutions with extremely low output ripple voltage (see Figures 3 and 4). Other features include a shutdown pin, which has an accurate 2.38V undervoltage lockout threshold and a 0.4V threshold for micropower shutdown (drawing only 25µA), and a SYNC pin, which allows the LT3430 to be synchronized up to 700kHz.

### Efficiency

Monolithic step-down converters capable of operation at high input voltages are usually optimized for efficiency at high input-to-output voltage differentials, where the duty cycle is low. At low duty cycles, DC switch losses are small compared to the overall losses, so the switch design is often neglected, resulting in a switch resistance that can be as poor as 0.5Ω for some 3A converters. Such converters give up efficiency at high duty cycle operation and limit their minimum input voltage operating capability.

LT, LTC and LT are registered trademarks of Linear Technology Corporation. FireWire is a registered trademark of Apple Computer Inc.

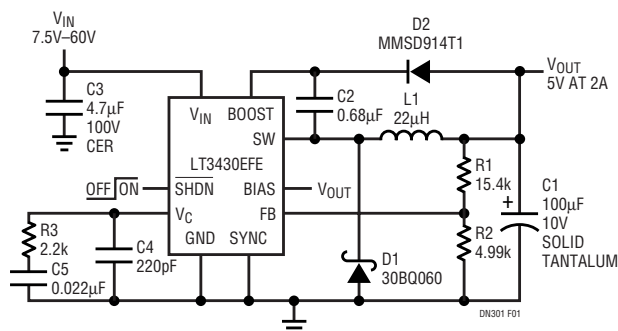

C1: AVX D CASE 100µF 10V TPSD107M010R0100  
 C2: AVX 0.68µF X7R 16V 0805YC684KAT1A  
 C3: UNITED CHEMI-CON 4.7µF 100V TCCR70E2A475M  
 C4: AVX 220pF X7R 50V 08055A221KAT  
 C5: AVX .022µF X7R 16V 0805YC223KAT  
 D1: INTERNATIONAL RECTIFIER 60V 3A SCHOTTKY 30BQ060  
 L1: SUMIDA 22µH CDRH104R

Figure 1. 42V to 5V Step-Down Converter

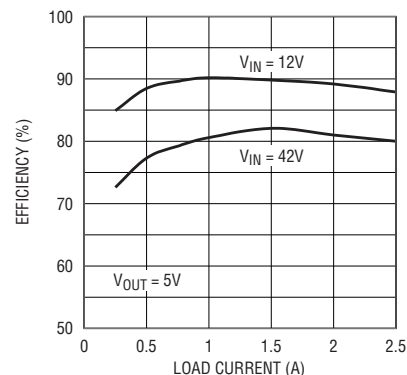

Figure 2. LT3430 Efficiency vs Load Current

Figure 1 shows a 42V to 5V converter using the LT3430. To achieve high efficiency at high input voltages, the LT3430 provides fast output-switch edge rates. To further improve efficiency, the LT3430 provides a BIAS pin to allow internal control circuitry to be powered from the regulated output—light loads at high input voltages require minimal quiescent current to be drawn from the input. The peak efficiency for a 42V to 5V conversion is greater than 82%, as shown in Figure 2.

The LT3430 is also capable of excellent efficiencies at lower input voltages. The peak efficiency for a 12V to 5V conversion is greater than 90%, as shown in Figure 2. One key to achieving high efficiency for low input-to-output voltage conversions is to use a low resistance saturating switch. A pre-biased capacitor, connected between the BOOST and SW pins, generates a boost voltage above the input supply during switching. Driving the switch from this boost voltage allows the 100mΩ power switch to fully saturate. An output voltage as low as 3.3V is enough to generate the required boost supply.

### Small Size, Low Output Ripple Voltage (High Switching Frequency, All Ceramic Solution)

The high 200kHz switching frequency of the LT3430 keeps circuits small by minimizing the inductor value required to keep inductor ripple current low. The current mode architecture of the LT3430 allows for a small, low ESR ceramic capacitor to be used at the output—thus providing an extremely low output ripple voltage solution in a small space. Figure 3 shows a 5V/2A low profile

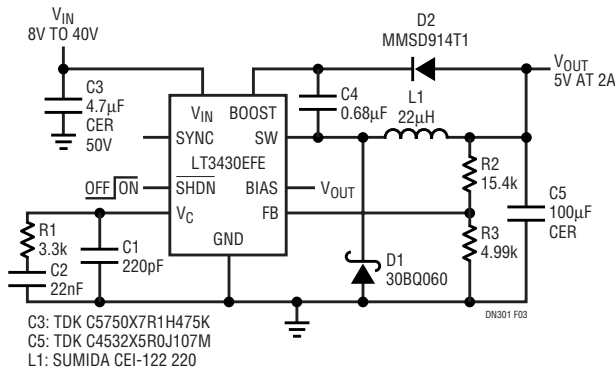

**Figure 3. Low Profile (Max Height of 3.0mm) Low Output Ripple Voltage Solution**

(<3mm) solution for FireWire peripherals which uses a ceramic output capacitor. The output ripple voltage of this circuit is only 26mV<sub>P-P</sub>, much less than the 80mV<sub>P-P</sub> incurred when a tantalum capacitor with an ESR of 80mΩ is used (see Figure 4).

### Peak Switch Current (Not Your Average Current Mode Converter)

Most current mode converters have a reduced peak switch current limit at high duty cycles. This is a result of slope compensation, which is added to the converter's current sensing loop to prevent subharmonic oscillations for duty cycles above 50%. However, the LT3430 is able to maintain its peak switch current limit over the full duty cycle range. For applications that require high duty cycles, this offers significant advantages—including a lower inductor value, lower minimum  $V_{IN}$  and/or higher output current capability—over typical current mode converters with similar peak switch current limits.

### Conclusion

The LT3430 features a 3A peak switch current limit, 100mΩ internal power switch and a 5.5V to 60V operating range, making it ideal for automotive, industrial and FireWire peripheral applications. It is highly efficient over the entire operating range and it includes important features to save space and reduce output ripple—including a 200kHz fixed operating frequency, a current mode architecture and availability in a small, thermally enhanced 16-pin TSSOP package.

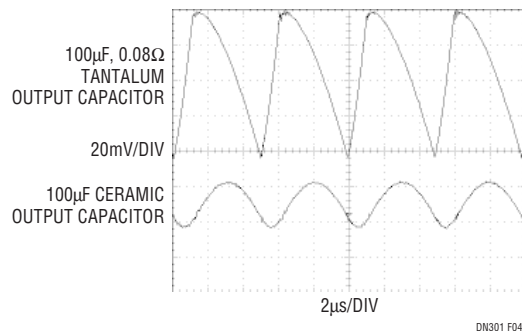

**Figure 4. Output Ripple Voltage Comparison for a Tantalum vs Ceramic Output Capacitor in the Circuit Shown in Figure 3 with  $V_{IN} = 24V$  and  $I_{OUT} = 2A$**

#### Data Sheet Download

<http://www.linear.com/go/dnLT3430>

For literature on our DC/DC Converters, call **1-800-4-LINEAR**. For applications help, call (408) 432-1900, Ext. 2759